

WPR

# STRATO EVO



YOUR WORK, SIMPLIFIED

STRATO EVO

YOUR WORK, SIMPLIFIED



WPR

STRATO EVO

# WITH STRATO EVO, WORKING BECOMES EASIER, FASTER AND MORE INTUITIVE

STRATO EVO is designed in response to the everyday needs of customers and the market.

At WPR, we have always strived to make work simpler and more efficient.



NOW WITH STRATO EVO, WE HAVE EVOLVED TO REDEFINE THE WORKING EXPERIENCE

**NO MORE STRESS**  
OF HAVING TO MANAGE EVERYTHING ON YOUR OWN

**SUPPORT AND GUIDANCE** AT EVERY STAGE OF OPERATION

A **CLEAR, PROACTIVE INTERFACE** ENSURES PRECISE, SAFE AND TIMELY PROCESS MANAGEMENT



**MORE CONFIDENT, MORE INDEPENDENT OPERATORS**

Intelligent systems and intuitive interfaces enable safe, efficient working.

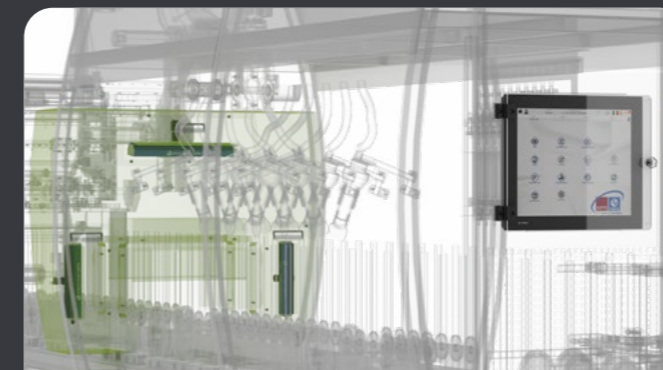

**CONSISTENT QUALITY**

The visual primer control system prevents errors and eliminates production waste.

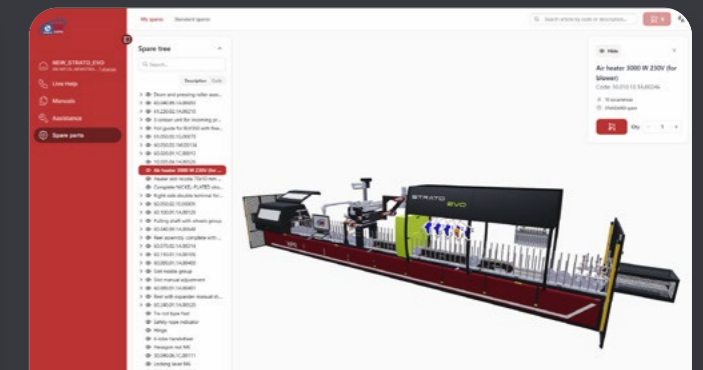

**ALWAYS-ON SUPPORT**

From the AI agent "EVA" to the MY HUB platform, assistance is accessible directly from the machine.



**MAXIMUM UPTIME**

Simplified maintenance and rapid diagnostics reduce downtime.



**OPTIMISED WORKSPACE**

Thanks to the repositioning of key components, the workspace is more accessible and easier to navigate.

## NEW OPERATOR PANEL : CLEAR AND PROACTIVE

The **completely redesigned** operator panel interface is the heart of the collaboration between your operators and the machine.

### EVERYTHING AT YOUR FINGERTIPS

CLEAR AND WELL-  
ORGANISED LAYOUT <

INTUITIVE FEATURES  
AND CONTROLS <

ALL FUNCTIONS,  
JUST A TAP AWAY <

### THE MACHINE THAT ACTIVELY SUPPORTS YOU

EVA, THE SYSTEM'S BUILT-IN  
AI AGENT, COMMUNICATES WITH  
OPERATORS THROUGH A SIMPLE CHAT <

PROACTIVE PANEL:  
INSTANT ALERTS FOR PROCESS AND  
MACHINE NOTIFICATIONS <

STRATO EVO.  
Where technology  
adapts to people.

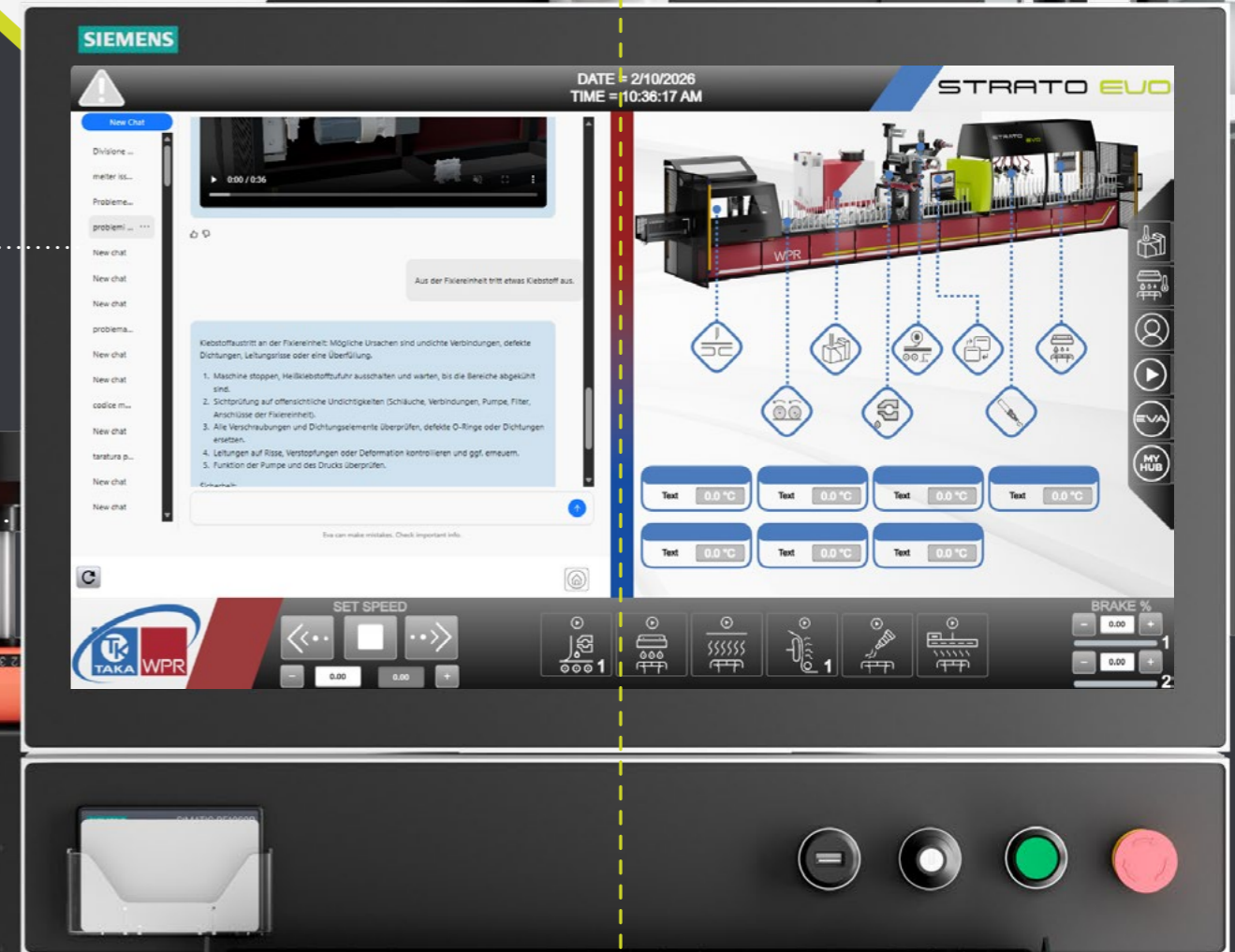

### SPLIT SCREEN MODE

The screen **splits into two sections**, giving operators a simultaneous view of all the information they need.

# AI AGENT INTEGRATED INTO THE OPERATOR PANEL

**EVA**  
The virtual agent  
that is a **real game  
changer**

**EVA**  
ASSISTANT

Simply type your query in  
natural language, just as  
you would when consulting  
an expert colleague

- > EVA understands your current operational context
- > She answers your questions
- > She offers proactive suggestions to optimise plant performance

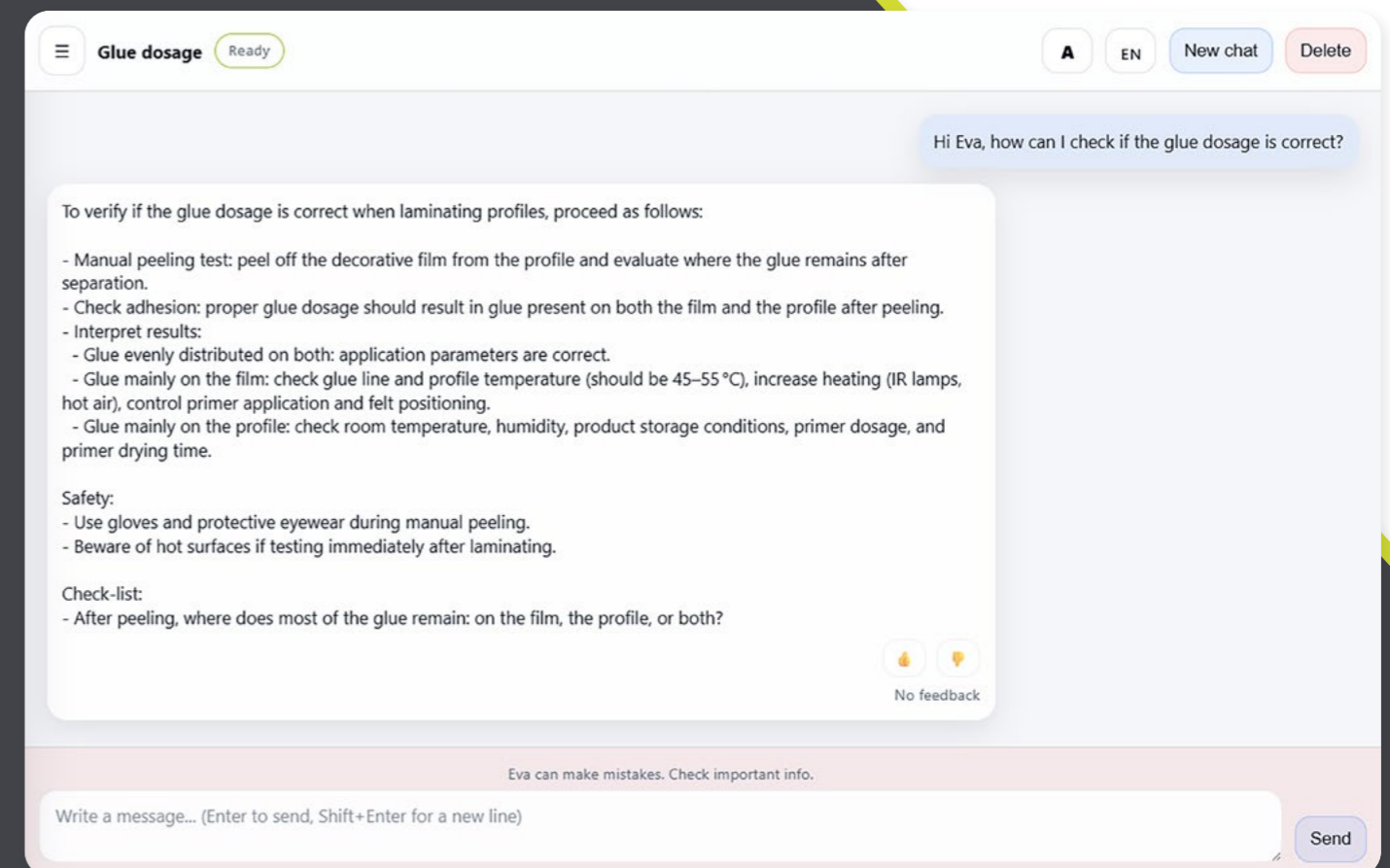
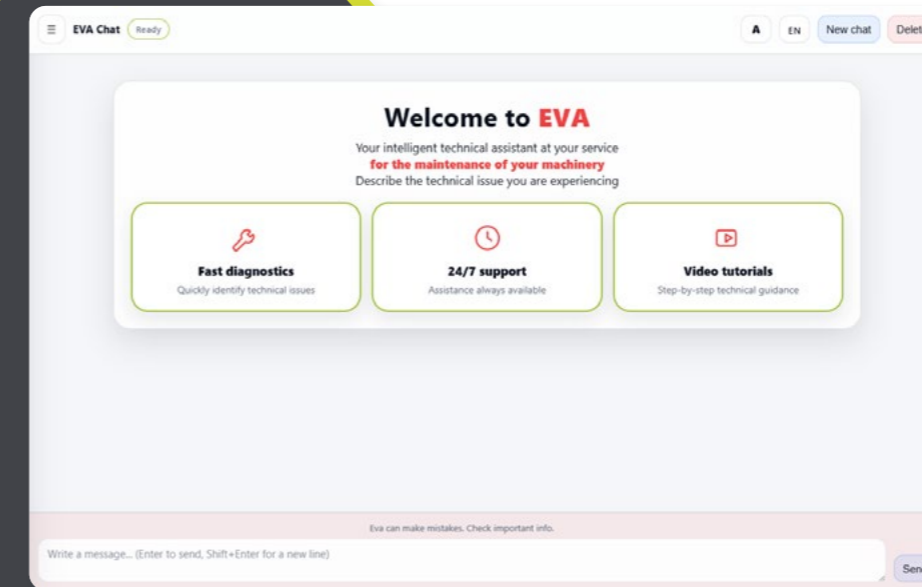

# FEATURES DIRECTLY ACCESSIBLE FROM THE OPERATOR PANEL

## YOU AT THE CENTER, ALWAYS

Direct access  
to WPR's MyHub.

Your digital support platform puts  
everything you need right at your  
fingertips.

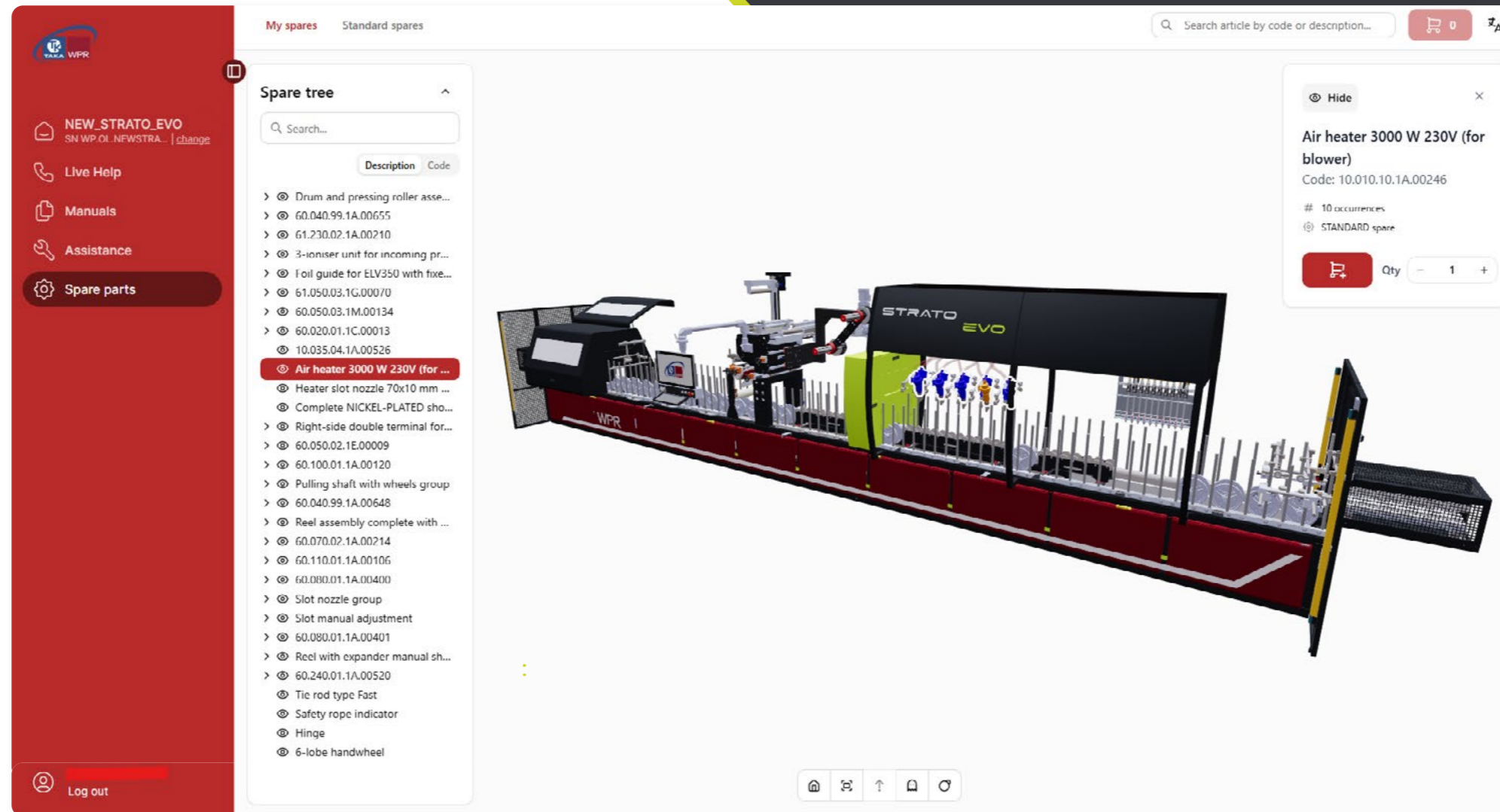

**MyHub:  
Smarter.  
Faster.  
More independent.**

### 24/7 spare parts orders:

Order at any time, even  
at midnight or over the  
weekend, with no need to  
contact a representative.

### Interactive 3D viewer:

Rotate, zoom and pinpoint  
the exact component you  
need, intuitively and  
directly from your machine.

### Real-time AR support:

Connect with one of  
our technicians for  
real-time assistance.

### Guided maintenance procedures:

Follow visual  
instructions for  
cleaning, replacement  
and inspection.

### Essential spare parts list:

A tailored list of  
recommended spare parts  
for every machine, so  
you always have what you  
need in stock.

# STRATO EVO

introduces a new

## VISUAL PRIMER CONTROL SYSTEM

**HIGH-RESOLUTION CAMERAS** with advanced optical filters verify the correct application of primer in real time.

- 👁 The system detects what is invisible to the naked eye
- ⚠ Should an anomaly occur, **the system alerts the operator** with a clear and timely alarm

### ADVANTAGES

- > FAULTS DETECTED AND DISPLAYED ON THE PANEL AT THE MACHINE'S INFEED
- > PROMPT INTERVENTION ENABLES A DRASTIC REDUCTION IN WASTE
- > CONSISTENT QUALITY GUARANTEED

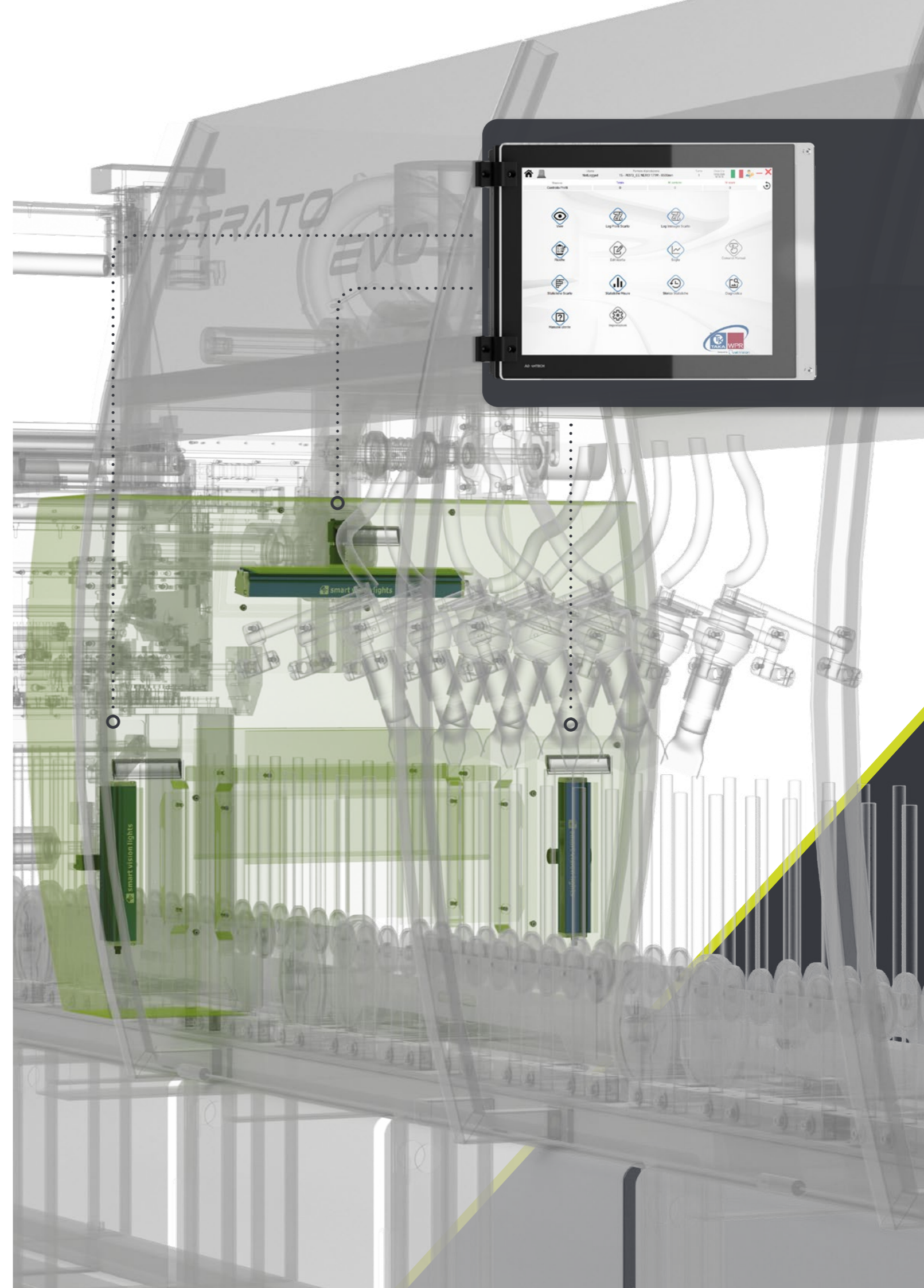

# ADAPTABLE PRIMER BOOTH

BUILT AROUND YOUR NEEDS



CONFIGURE THE BOOTH  
TO **SUIT THE PRIMER YOU USE**

**UPGRADE AVAILABLE**  
WHEN SWITCHING PRIMER TYPE

## ADVANTAGES

- > CONFIGURED TO SUIT YOUR PRIMER OF CHOICE
- > MODULAR DESIGN TO MATCH YOUR WORKING SPEED AND LENGTH OF MACHINE
- > HEATING DISTRIBUTION SYSTEM INTEGRATED DIRECTLY INTO THE BOOTH



### MORE SPACE, GREATER ACCESSIBILITY

- > Completely redesigned interior layout
- > The central blower is now integrated above the booth, freeing up valuable operational space
- > Air tubes run from above, giving operators far easier access and making the work area tidier and more functional

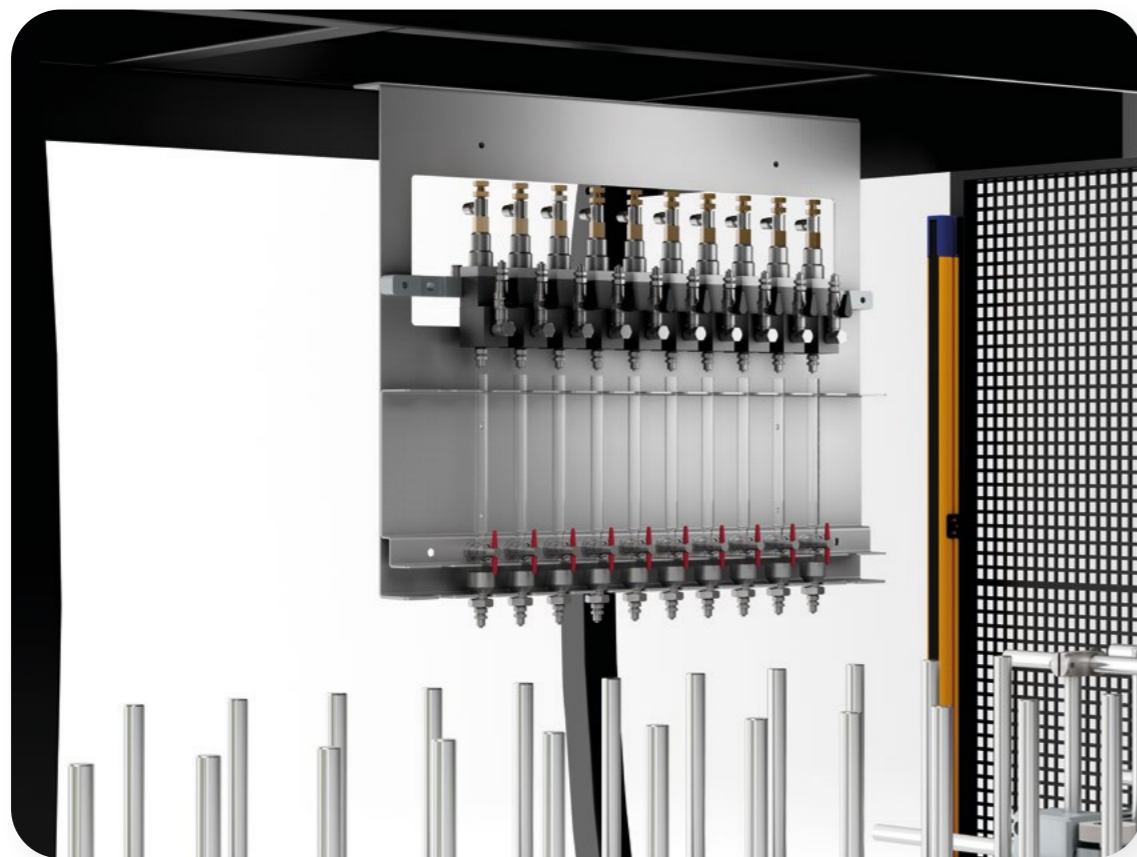

### SIMPLIFIED PRIMER CALIBRATION

- > The graduated test tubes remain in a fixed position and are fitted with a practical tap
- > Instant switchover from calibration to production start
- > No risk of damage or loss of test tubes: ensuring safety, simplicity and speed

# PROTECTING THROUGH TECHNOLOGY, REASSURING THROUGH SIMPLICITY.

Safety is **non-negotiable**.

.....  
A workplace accident carries a human and economic cost that no company can afford to face.

> **NEW OPTICAL BARRIER SYSTEM**

> **INTEGRATED LEDs enable:**

> Immediate error signalling

> A fast and intuitive procedure thanks to the simplified alignment of the guide LEDs

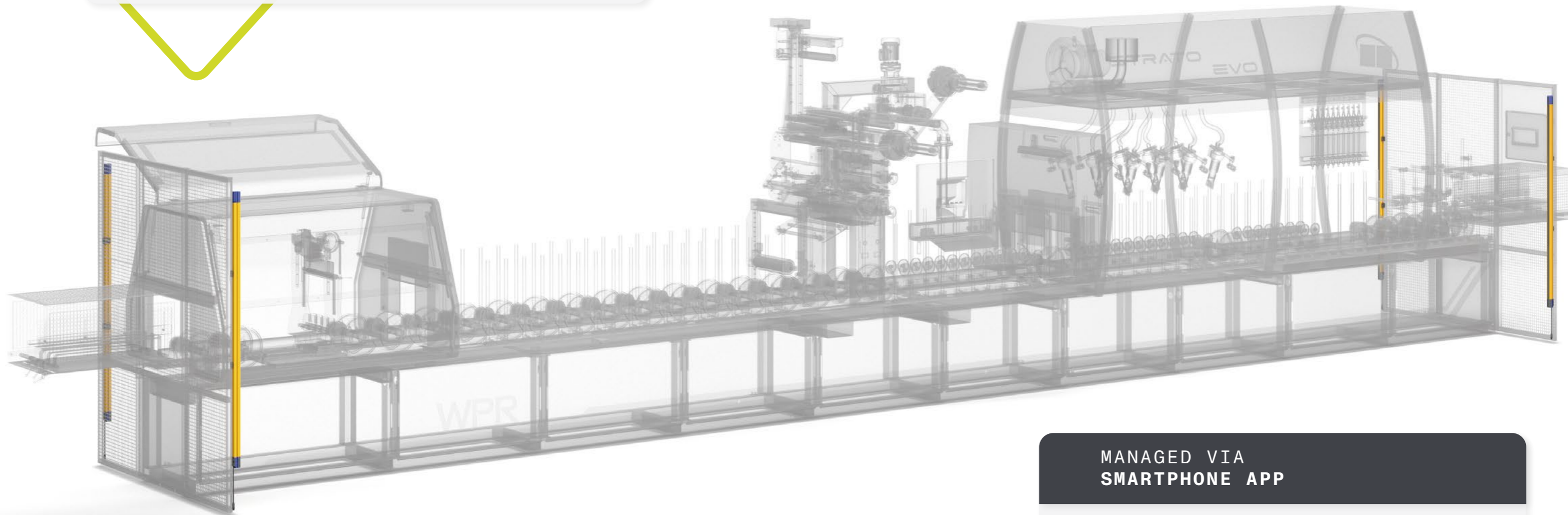

MANAGED VIA  
SMARTPHONE APP



YOUR TECHNICIANS CAN **CONFIGURE, MONITOR** AND **DIAGNOSE** THE SAFETY SYSTEM STRAIGHT **FROM THEIR PHONE** – NO SPECIALIST EQUIPMENT, NO COMPLICATED PROCEDURES.

STRATO EVO

YOUR WORK, SIMPLIFIED

STRATO EVO



**W.P.R. srl Unipersonale**

Via Indipendenza, 10  
31027 Spresiano (TV)  
Italia

Tel +39 0422 911849

Fax +39 0422 911292

Email [info@wpr.it](mailto:info@wpr.it)

[wpr-machines.com/](http://wpr-machines.com/)

**TAKA srl**

Via dell'Industria, 4  
36060 Pianezze (VI)  
Italia

Tel +39 0424 411166

Fax +39 0424 411727

Email [info@taka.it](mailto:info@taka.it)

[taka-adhesives.com/](http://taka-adhesives.com/)